

## Intrinsically safe telephone iVT3\*\*

### Ordering Data



Designation	Type	Item no.
Intrinsically safe telephone with battery	iVT3	112 503 01 AX
Intrinsically safe telephone without battery	iVT3	112 503 11 AX
Intrinsically safe telephone with rechargeable battery	iVT3	112 503 02 AX
Intrinsically safe telephone without rechargeable battery	iVT3	112 503 12 AX
Intrinsically safe telephone with rechargeable battery for local battery exchange iST	iVT3	112 503 03 AX
Intrinsically safe telephone without rechargeable battery for local battery exchange iST	iVT3	112 503 13 AX
<b>Optional extra</b>		
Battery module, alkaline-manganese mono cells 9V/15Ah	9704U6	118 895 01 AX
Rechargeable battery module NiCd 7.2 V / 0.5 Ah	9704U8	118 896 01 AX
Fastening set		112 941 01
<b>System optional extras</b>		
Telephone coupler with alarm	iKT1-A2	118 807 09 AX
Intrinsically safe telephone coupler	iKT2	118 810 01 AX
Intrinsically safe local battery exchange	iST	118 810 05 AX
Rack for iKT1-...	7933	118 807 05
Telephone coupler link e / i	KT1	118 809 01 AX
Telephone coupler	sG2148	333 006 01 AX
Telephone coupler	sB2248	333 003 49 AX
Converter module	2313	118 306 01 AX
Intrinsically safe blink lamp	iBL1	118 811 01 AX
Ringling - Loudspeaker (200 Ω)	5801K	123 720 03 AX
Loudspeaker (16 Ω)	iLA3/16	123 620 03 AX
Emergency call button	iBS*	xx AX
<b>Spare parts</b>		
Electronic insert	9704U002A000-BT	112 503 91 AX
Electronic insert local battery telephone		112 503 91 01 AX
Electronic insert export		112 503 91 11 AX
Handset with armoured cord	9700U003A011-BT	112 503 92 AX
Handset with spiral cord	9700U003A100-BT	112 503 92 01 AX
Cover with keypad	904U007A000	112 503 93 AX
Display and wiring plate		112 503 94 AX
Loudspeaker ringling sound / hands-free	9704U015A000	112 503 95 AX

- **Intrinsically safe analogue telephone with dual-tone multifrequency**
- **Category / Type of protection I M1 EEx ia I**
- **Variable energy supply through:**
  - **Battery module (15 Ah)**
  - **Local supply with buffering through NiCd rechargeable battery module (0.5 Ah)**
- **Display for operating support and simple setting by the operator of all important parameters (German/English)**
- **Access/locks through PIN**
- **5 menu function keys in the display**
- **Calling from telephone book**
- **Last number redial**
- **Loudspeaker key**
  - **Make a phone call without lifting the handset – handsfree**
  - **Listening-in when the handset is off the hook – open listening**
  - **Terminal function**
- **Disconnect key (clearing key)**
  - **Begin a new call without putting back the handset**
- **R key (flash) for call forwarding**
- **Two independent, potential-free opto-couplers – contact outputs for actuation of additional, acoustic or optical signalling devices (call (ringing) / alarm call)**
- **Output for ringing indicator (blink lamp iBL1)**
- **In combination with the telephone couplers this results in a completely intrinsically safe feature, alarm and emergency call telephone, as well as a shaft (local battery) telephone**

**External connections:**

- **Loudspeaker for loud distribution of the ringing signal and alarm announcements**
- **Loudspeaker for loud distribution of the ringing signal and alarm announcements**
- **Varieties of the telephone for the function:**
  - **Alarm-emergency call telephone**
  - **Shaft (local battery) telephone**

### Description

The intrinsically safe telephone iVT3\*\* is designed in the I M1 EEx ia I category / type of protection and may be used unconditionally in intrinsically safe telephone systems of Type 5210/3 or alarm telephone systems of Type TA1 (approved telephone systems from FHF Bergbautechnik) in explosive atmospheres in the mining industry.

The associated converter (Type 2313, sG2148, sB2248, iKT1-A2, KT1) separates the intrinsically safe part of the telephone system securely from the non-intrinsically safe telephone network.

**The intrinsically safe telephone iVT3\*\* only works with the above-mentioned converters and is not fit for direct connection to private branches or public telephone networks!**

The designated power supply is primary batteries as local battery (battery module Type 9704U6) or the use of NiCd rechargeable batteries (rechargeable battery module Type 9704U8) with a local supply.

When locally feeding the NiCd rechargeable batteries through an intrinsically safe power supply unit Type NG3-12ib, the supply voltage is buffered through a NiCd rechargeable battery (rechargeable battery module Type 9704U8) inserted in the iVT3\*\*. This enables safe telephone calls and alarms even without cyclic battery changes and even if the mains supply has been switched off.

A loudspeaker can be connected to the telephone for loud distribution of the ringing signal tone in noisy areas.

As a feature telephone, the iVT3\*\* offers the following performance features:

- Handset mode
- Handsfree listening
- Handsfree speaking
- Normal dialling
- Last number redial
- Dialling from telephone book
- Disconnect key
- R key (Flash)
- Volume control for handset (listening and speaking) and loudspeaker.

### Design

The housing material of telephone iVT3\*\* consists of unvarnished, electrostatically conductive plastic cast-moulding. The housing consists of a rectangular lower part and a desk-shaped cover (1) with a stainless steel keypad (material V4A). A dual spacing of 20 mm between the function keys and 22 mm between the dialling keys warrant secure operation, even with gloves. The keypad front plate contains a display sealed by a viewing window.

The housing is corrosion proof, robust and offers protection against dust and humidity according to IP54 and IP66, respectively.

The lid is swivel-mounted on two hinges on the lower part of the housing. A surrounding seal is placed between the lid and the lower part of the housing, which are pressed together by four screws (2).

Bores for five cable entries are available on the bottom of the housing.

Unused entries are closed by blind plugs. The cable entries serve, among other things, to insert the telephone network line (subscriber line) and the handset line, call indicator or loudspeaker. The standard version of the telephone is equipped with two factory-installed cable entries that are at the user's disposal.

The electronic insert, which is completely embedded in a block of protective compound, is situated on the left-hand side of the main room of the lower part of the housing. The terminals protrude from the compound. Also embedded, on the right-hand side, there is either a battery module or a rechargeable battery module for buffering the local supply.

Robustly designed, the handset is protected against damage and the intrusion of dust and moisture. An internal protective foil provides effective protection of the mouthpiece (microphone) and earpiece. The handset is held by two latches in an accommodation on the upper side of the device.

The force required to hold the handset may be steplessly adjusted. After loosening the screws (3), the latches (4) can be shifted. Pushing the latches together, increases the holding force, pulling them apart, reduces it. Tightening the screws (3) fixes the setting.

The „hook switch“ has been realised as a reed switch inside the housing, and is actuated by removing/replacing the handset (using the magnetic stray field of the earpiece)

### Device overview

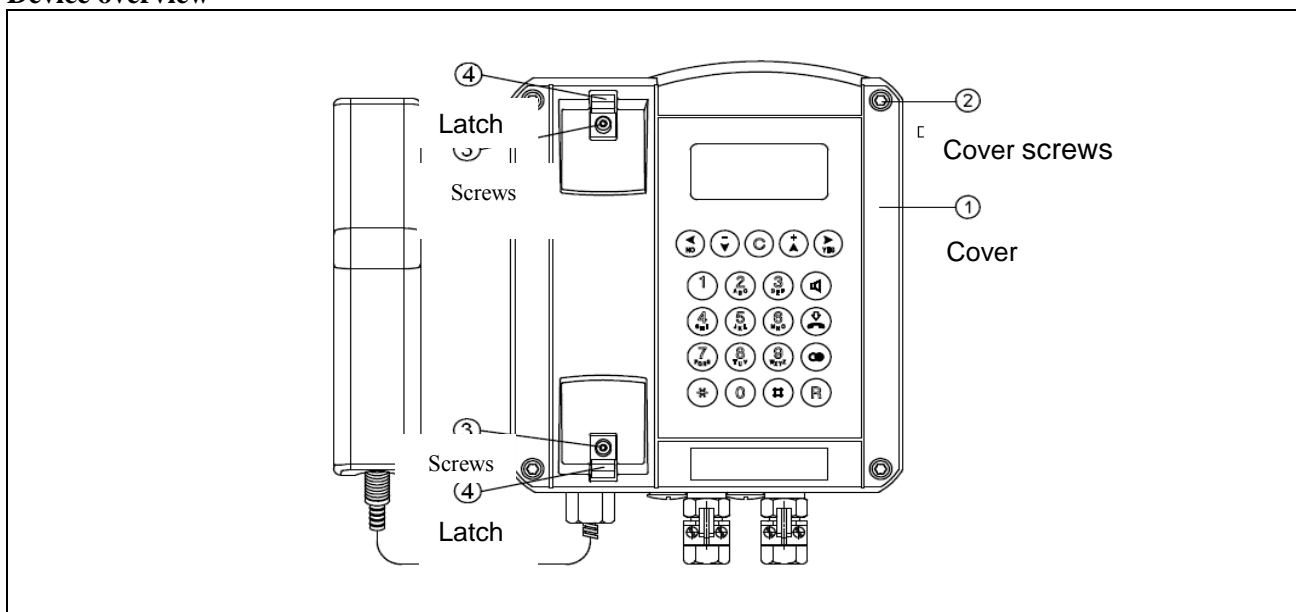

Dimensions

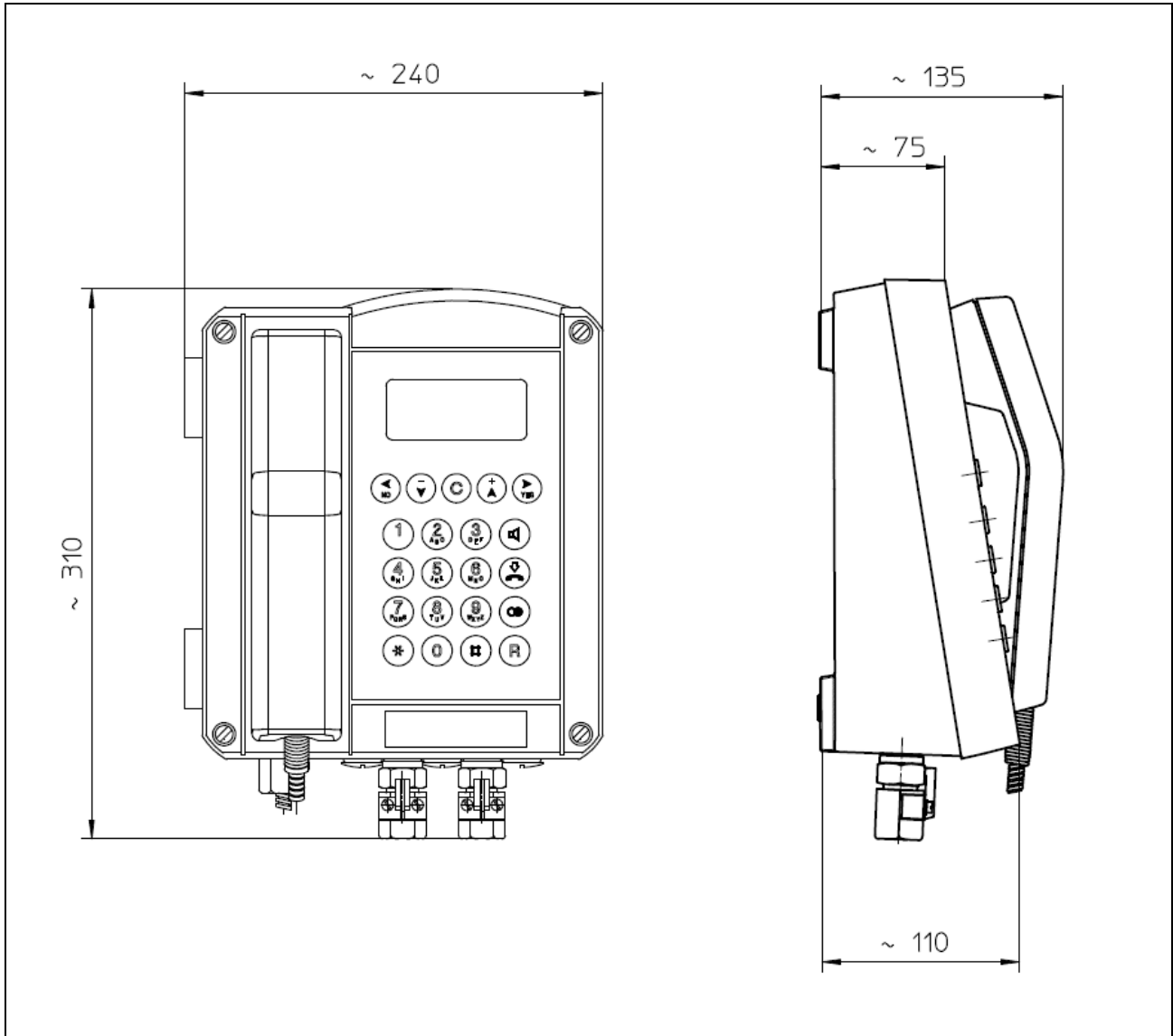

Internal design

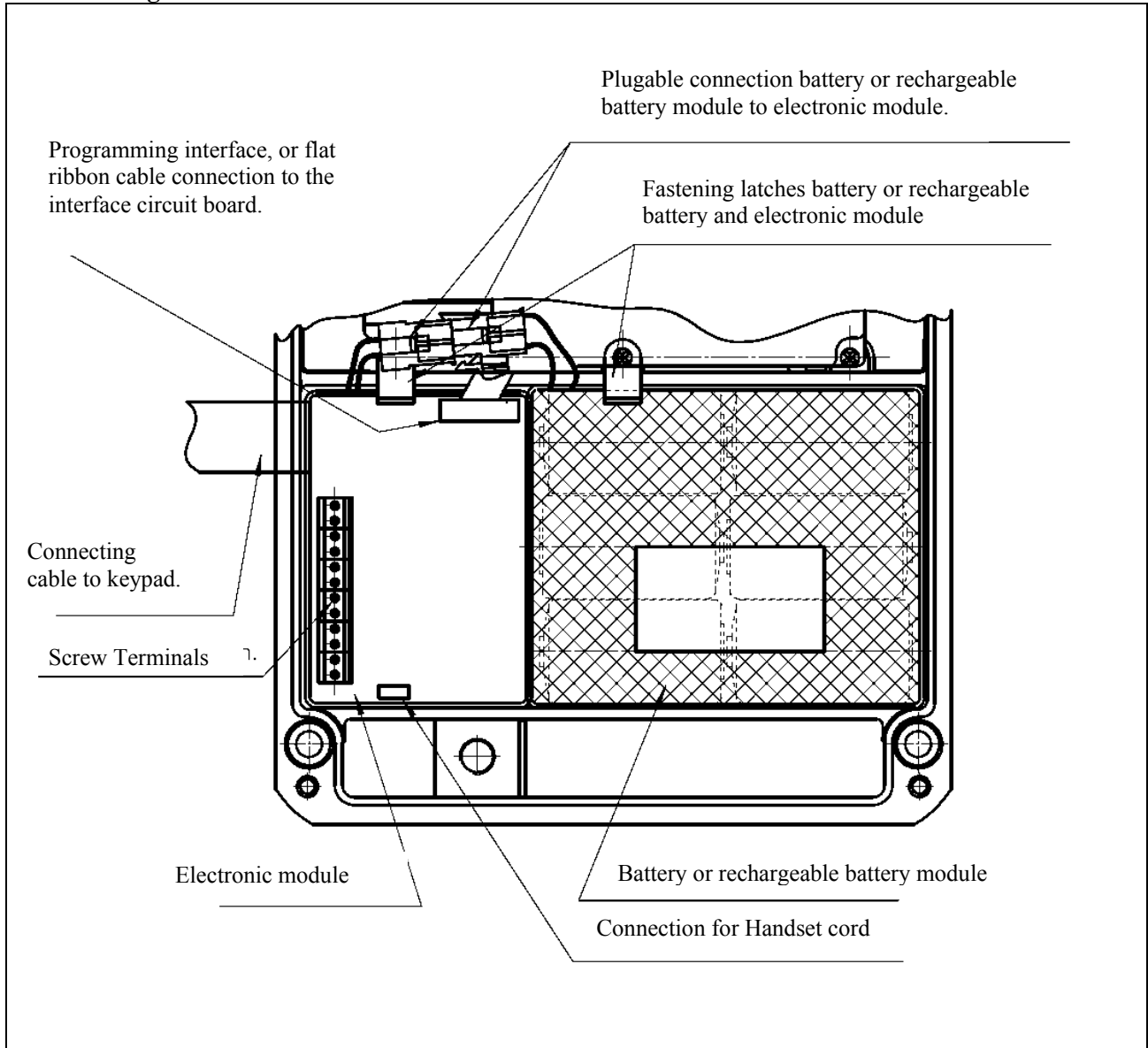

## Display and keypad

### Function keys

Using these keys, you can change the settings directly, or make permanent changes in the menu.

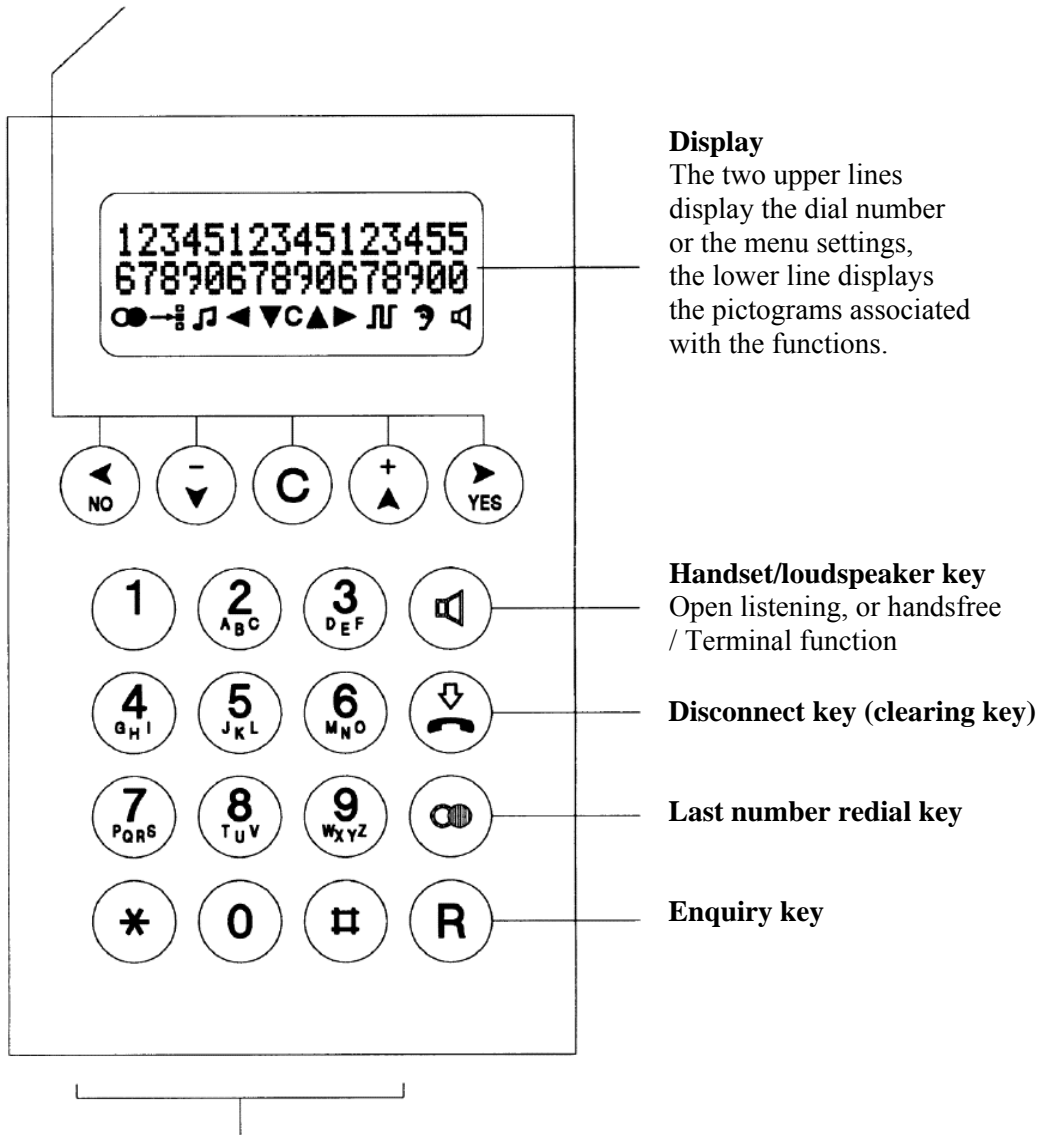

### Display

The two upper lines display the dial number or the menu settings, the lower line displays the pictograms associated with the functions.

### Handset/loudspeaker key

Open listening, or handsfree / Terminal function

### Disconnect key (clearing key)

### Last number redial key

### Enquiry key

### Number keys

Using these keys, you can enter the numbers (digits) and texts.

**Technical data iVT3\*\***

Name	Intrinsically safe telephone
Type	iVT3**
<b>Electrical characteristics</b>	
<b>Output contact CALL</b>	Terminal 1 (AR+) and terminal 2 (AR-)
Potential-free opto-coupler electric circuit for external signalling devices	
Max. input voltage $U_i$	24 V
Max. input current $I_i$	1 A
Max. input power $P_i$	24 W
Max. internal capacitance $C_i$	negligible
Max. internal inductivity $L_i$	negligible
<b>Output contact ALARM</b>	Terminal 3 (AA+) and terminal 4 (AA-)
potential-free opto-coupler electric circuit for external signalling devices	
Max. input voltage $U_i$	24 V
Max. input current $I_i$	200 mA
Max. input power $P_i$	500 mW
Max. internal capacitance $C_i$	negligible
Max. internal inductivity $L_i$	negligible
<b>Output for ext. loudspeaker</b>	Terminal 5 (LSP1) and terminal 6 (LSP2)
Max. output voltage $U_o$	9.9 V
Max. output current $I_o$	0.91 A
Max. output power $P_o$	1.42 W
Max. external capacitance $C_o$ ( $L_o=0$ )	80 $\mu$ F
Max. external inductivity $L_o$ ( $C_o=0$ )	0.5 mH
<b>Ext. signalling device output</b>	Terminal 7 (B+) and Terminal 8 (B-)
Max. output voltage $U_o$	9.9 V
Max. output current $I_o$	3.64 A
Max. output power $P_o$	2.72 W
Max. external capacitance $C_o$	80 $\mu$ F
Max. external inductivity $L_o$	30 $\mu$ H
<b>Telephone-network line a/b</b>	Terminal 9 (a) and terminal 10 (b)
Max. output voltage $U_o$	9.9 V
Max. output current $I_o$	130 mA
Max. output power $P_o$	295 mW
Max. external capacitance $C_o$ ( $L_o=0$ )	80 $\mu$ F
Max. external inductivity $L_o$ ( $C_o=0$ )	25 mH
<b>External emergency key connection</b>	Terminal 11 (NT1) and terminal 12 (NT2)
Max. output voltage $U_o$	9.9 V
Max. output current $I_o$	3 mA
Max. output power $P_o$	60 mW
Max. external capacitance $C_o$ ( $L_o=0$ )	80 $\mu$ F
Max. external inductivity $L_o$ ( $C_o=0$ )	1 mH
<b>Charging connector for rechargeable battery</b>	Terminals DC+/DC- on rechargeable battery module type 9704U8
Max. input voltage $U_i$	13 V
Max. input current $I_i$	1.3 A
Max. internal capacitance $C_i$	negligible
Max. internal inductivity $L_i$	negligible



**Technical data iVT3\*\***

**General data**

Current consumption	
Standby	≤ 40 µA
Call condition	≤ 12 mA
Ringing signal / alarm announcement	approx. 200 mA
Supply voltage range	6 V ≤ U <sub>batt</sub> ≤ 10V
Charge current rechargeable battery module type 9704U8	approx. 22 mA
Supply voltage range	
Charge input rechargeable battery module type 9704U8	8 – 13 V
Loop current a/b	approx. 1.8 mA
Clamping capacity of the terminals	up to 2.5 mm <sup>2</sup> fine-wired
Ringing tone volume:	100 dB(A) at 1m distance (with iLA3/16)
Alarm text volume:	100 dB(A) at 1 m distance
Battery module type 9704U6	9 V / 15 Ah / alkaline-manganese mono cells
or	
Rechargeable battery module type 9704U8	7.2 V / 0.5 Ah / NiCd
Degree of protection according to EN60529	IP54 / IP66
Operating mode	100 % Continuous operation
Operating position	Vertical mount, cable glands facing downwards
Operating conditions	Preferably within hazardous areas
Ambient operating temperature – ranges:	
Electronic module	- 20°C ... + 40°C
Battery module type 9704U6	- 20°C ... + 40°C
Rechargeable battery module type 9704U8	0°C ... + 40°C
Dimensions	se dimensions illustration
Weight	approx. 6 kg
- Type of protection	I M 1 EEx ia I
- Approval	BVS 06 ATEX E 014 X

**Labelling**

The nameplate of the intrinsically safe telephone iVT3\*\* is identified as follows:

Company	FHF Bergbautechnik D-42551 Velbert
Type	iVT3**  I M 1 EEx ia I BVS 06 ATEX E 014 X  0158 F-No.... Examination....(Manufacturing number, Abbreviation, month/year) Intrinsically safe systems only

The following identification is shown on the nameplate of the electronic module type 9704U2:

Company	FHF Bergbautechnik D-42551 Velbert
Type	9704U2  I M 1 EEx ia I BVS 06 ATEX E 014 X 0158
Production-No.	xxxx
P/N	xxxx F-No.... Examination....(Manufacturing number, Abbreviation, month/year) Intrinsically safe systems only

**Technical data iVT3\*\***

The nameplate of the battery module type 9704U6 is identified as follows:

Company	FHF Bergbautechnik D-42551 Velbert
Type	9704U6  I M 1 EEx ia I BVS 06 ATEX E 014 X 0158 F-No.... Examination....(Manufacturing number, Ab- breviation, month/year) Intrinsically safe systems only

The nameplate of the rechargeable battery module type 9704U8 is identified as follows:

Company	FHF Bergbautechnik D-42551 Velbert
Type	9704U8  I M 1 EEx ia I BVS 06 ATEX E 014 X 0158 0°C ≤ T <sub>a</sub> ≤ +40°C F-No.... Examination....(Manufacturing number, Ab- breviation, month/year) Intrinsically safe systems only

### Mounting and installing

The iVT3\*\* telephone is designed for vertical wall mounting (cable entries facing downwards).

It is fastened on the site of operation by four screws (max. diameter 8mm). This is done by loosening the lid screws and swinging the upper part aside. The four screws with a head diameter of 10 to 13 mm are inserted into the corresponding mounting holes in the lower part of the housing and screwed into the firm surface below. The diameter of the bores in the mounting surface depend on the screws used and the type of surface (steel, wood, concrete etc.) and must be chosen accordingly.

(Note: Mounting lugs are available as optional extras)

For making a drilling template, please use the following dimensions (in millimetres).

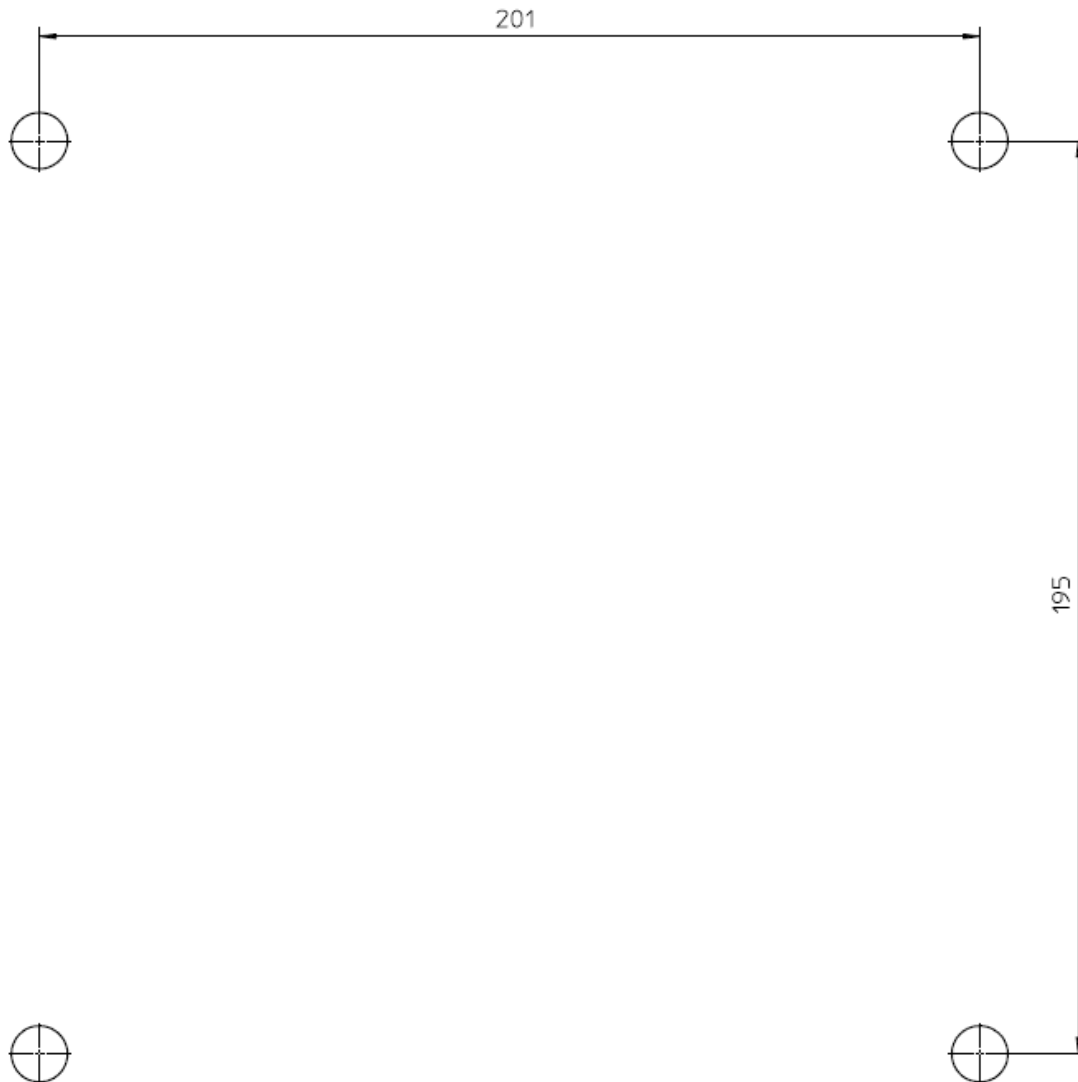

**Connection**

The terminal block should be connected according to the following wiring diagram.

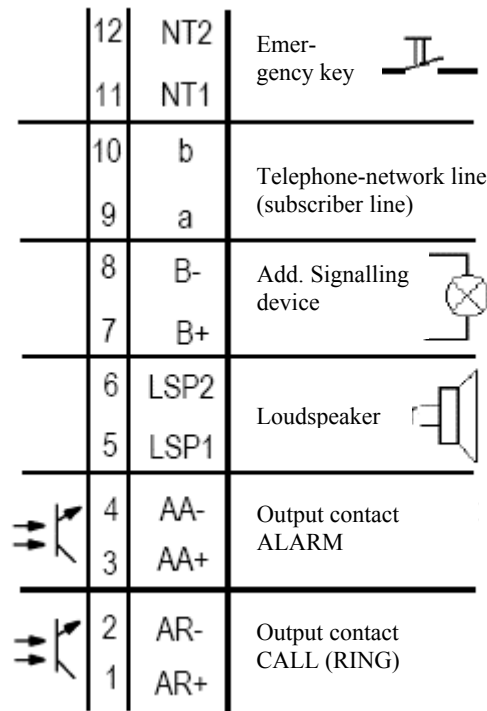

The following connections are wired to the terminal block:

- Terminal 1                    AR+ output contact CALL (RING), positive connection
- Terminal 2                    AR- output contact CALL (RING), negative connection
- Terminal 3                    Floating (potential free) output for external calling devices (e.g. iBL1)
- Terminal 4                    AA+ output contact ALARM, positive connection
- Terminal 5                    AA- output contact ALARM, negative connection alarm output.
- Terminals 5 and 6            Floating (potential free) output for external signalling devices
- Terminal 7                    LSP1, LSP2, loudspeaker (external)
- Terminal 8                    B+ signalling device, positive connection
- Terminal 9                    B- signalling device, negative connection
- Terminal 10                  Switched output circuit of battery or rechargeable battery, for instance for connection of an intrinsically safe call indicator (type iBL1)
- Terminal 11                  a telephone-network line, negative connection
- Terminal 12                  b telephone-network line, positive connection
- Terminals 11 and 12        NT1, NT2 emergency key (external)

## **Maintenance (Service)**

The device is supplied by a battery module 9 V / 15 Ah Type 9704U6 or a rechargeable battery module NiCd 7.2 V/0.5Ah Type 9704U8. Empty battery modules or defective rechargeable batteries must be replaced. The replacement modules should be transported in a robust, closed, antistatically effective container, which protects them from the influence of the ambient conditions (moisture, dust, draught... ). The container must be designed in order to protect the replacement modules from mechanical damage, too, if they fall down or receive impacts.

Replacing the modules

Open the housing cover (4 cover screws) and swing it sideways. Loosen the screws of the module fastening latches and turn it to the side.

When replacing the rechargeable battery, first disconnect the supply cable from the terminals DC-(1) / DC+(2) on the rechargeable battery module.

Then pull off connector X101, turn the holding latch to the side, remove the battery or the rechargeable battery from the telephone and insert the replacement in the same place.

Then, turn the module fastening back in place and screw it on tightly. Close the telephone cover according to the instructions.

The replaced modules must be taken away in a suitable container, as described above.

Replaced, empty, defective modules must be disposed of according to local laws and regulations.

## **Setup for operation**

Open the telephone using the four cover screws. Lay the telephone-network (subscriber) line and the connecting cables of the optional devices through the cable glands, tighten the glands in order to seal them and enable their function as tensile strength reducers. Connect the correctly de-isolated wires of the cables to the correct terminals. The corresponding connection illustration can be found on the electronic insert.

Battery operation:

Connect the battery connection receptacle with the corresponding plug in the device.

Rechargeable battery operation:

Connect the local intrinsically safe supply source to the rechargeable battery module terminals (observe the polarity). Then connect the rechargeable battery connection receptacle with the corresponding plug in the device.

Close the telephone cover and tighten the cover screws.

During commissioning, please conduct the following necessary parameterisations.

The telephone will then be ready for operation.

## **Operation**

### General operation

1. The telephone iVT3\*\* has been designed (by use of appropriate telephone couplers) for connection to analogue access points (ports) of PBX.
2. The handset is equipped with a stray field coil for coupling of hearing aids. Users of a hearing aid with inductive detector may receive the signal from the handset inset directly.
3. The telephone has a handset bracket with a reed (magnetic) contact as hook switch. To disconnect, replace the handset or press the Disconnect key on the keypad. When the disconnect key is pressed, the telephone disconnects the line and shortly afterwards automatically occupies the line again, so you can make a new call.
4. Please use the menu to program telephone properties and settings. To do this, lift the handset (or press the loudspeaker key), then press the „YES“ key.
5. Three short tones notifies you of incorrect entries or settings.
6. When someone calls you, the telephone rings with the volume and the ringing tone you have set. For the duration of the ringing tone, a message also appears in the display.
7. To restrict access to the telephone settings or to the telephone, you must enter a PIN. Forgetting your PIN can be compared to loosing a key. If you have forgotten your PIN, please contact our technical support service.
8. Opening the cover is equivalent to lifting the handset; the telephone is activated.

## **Make a phone call**

### **Operating modes**

#### Handset mode

If you lift the handset, the telephone is in handset mode. Use the „+“ and „-“ keys to change the handset volume for the call. If you want to change the handset volume permanently, please use the menu „Settings / Telephone / Volume / Handset / Listen“ to set the receiving side, and the menu „Settings / Telephone / Volume / Handset / Talk“ to set the talking side. Press the loudspeaker key to go to loudspeaker mode. If you keep the loudspeaker key depressed and hang up the handset, you go to handsfree mode.

#### Handsfree listening mode

Use the „+“ and „-“ keys to change the loudspeaker volume for this call. If you want to change the loudspeaker volume permanently, please use the menu „Settings / Telephone / Volume / Loudspeaker“. While the telephone is in handsfree listening mode, the handset volume cannot be changed. Press the loudspeaker key to go to handset mode. If you keep the loudspeaker key depressed and hang up the handset, you go to handsfree speaking mode.

#### Handsfree speaking mode

If you turn on the telephone by pressing the loudspeaker key, the telephone enters handsfree speaking mode. Use the „+“ and „-“ keys to change the loudspeaker volume for this call. If you want to change the loudspeaker volume permanently, please use the menu „Settings / Telephone / Volume / Loudspeaker“. Press the loudspeaker key to terminate the call. If you lift the handset, the telephone enters handset mode.

#### Pick up, occupy the line

If you pick up the handset or press the loudspeaker key, the telephone is activated. This applies a loop current to the telephone-network (subscriber) line. This current is detected in the telephone coupler and initiates the occupation of the subscriber port in the private branch exchange. You hear the dial tone (line-free signal) in the handset or loudspeaker.

#### Make a call

You dial a number by pressing the corresponding digit keys.

#### Last number redial

Having occupied the line, press the last number redial key. The number you called last is displayed and dialled.

#### Dialing from telephone book

Having occupied the line, you may press the keys “YES”, “YES” to go to the telephone book. Press the „+“ and „-“, keys to search for the desired name or telephone number. If the name you are looking for, is displayed, press „YES“ twice, and the telephone dials the number stored under this name.

#### Hang up (replace the handset), disconnect

In handset mode and in loudspeaker mode, you end a call by hanging up (replacing) the handset. In handsfree mode you end a call by pressing the loudspeaker key. The line is no longer occupied in the private branch exchange, and the telephone switches to stand-by mode.

When the disconnect key is pressed, the telephone disconnects the active line and shortly afterwards automatically occupies a line again, so you can enter a number and make a new call.

#### Stand-by mode

In the stand-by mode, only the ringing signal detector is active. This means the power consumption is at a minimum. Depending on the type of pre-connected telephone coupler ( 2313, sG2148, sB2248, iKT1-A2 or KT1), the PBX ringing signal (25 Hz or 50 Hz) voltage is limited, or the ringing signal is converted into a 300 Hz signal. The telephone is activated, and it responds corresponding to its configuration.

In the feature telephone version, a ringing tone sounds over the loudspeaker. In case of an existing, external loudspeaker, the ringing tone can also be sent via this external loudspeaker. Melody and volume of the ringing tone are programmable. You can also program the ringing signal to actuate a potential-free contact. Hereby, you can set ring-pause bridging.

In the alarm telephone version, the length of the ringing signal is measured, and the call is defined as a normal telephone call, an alarm call or a test call. If it is a normal or alarm call, a ringing tone is sounded over the internal and especially loud over the external loudspeaker. Here, too, the volume of the ringing tone can be programmed. The frequencies used for the ringing tone, can be set. A test call is not signalled over the loudspeaker.

In the shaft telephone version, a ringing signal is awaited. Thereafter, the iVT3\*\* decides, within a limited time, if the number signalled over the remote line is its own two-digit number or the group number. If it recognises the own or the group number, the iVT3\*\* sounds the ringing tone over the loudspeaker.



In all cases, lifting the handset or pressing the loudspeaker key answers the call. If the handset is not picked up, the telephone, after a programmed number of ringing tones, returns to stand-by mode. Replacing the handset or pressing the loudspeaker key ends a call, and the iVT3 returns to stand-by mode.

## Programming



### General

Use the Programming menu to set the settings for the operation of the iVT3\*\* telephone.

After lifting the handset or pressing the loudspeaker key, a welcome message appears in the display. Press the  key to enter the Programming menu.

In the top line of the display, the text „Main menu“ appears. In the second line, you see the first menu item of the Main menu. The arrow > in front of the menu item indicates that this item has been selected. By pressing the  key repeatedly, you go to the next menu items. Using  you return to the top of the table of menu items.

The display shows two menu items at a time. When an arrow > is visible in front of an item, it indicates that the item has been selected.

The menu items denote further sub-menus. Pressing the  key, activates a selected menu item. Any sub-menu may contain further sub-menus as menu items. These menu items are selected in the same manner as in the Main menu. Press the  key to go to a higher menu, or to leave the Main menu.

At the sub-menu levels, the selection or activation/deactivation of options is indicated by so-called feature selector () or check boxes [X].

#### Example of feature selector



Display	Significance
---Activate---	Title line
(●) Not any	Activated option
(●) Direct call	Option
>(●) Total Lock	Selected option
(●) Telephone book	Option
=== End===	End of the menu table



Feature selectors allow for one selection only. An option is selected by pressing the C key.

#### Example of checkbox

Display	Significance
---Switch on---	Title line
[X] Phone Call	Activated checkbox
>[X] Alarm Call	Selected checkbox
=== End===	End of the menu table

In checkboxes, any and all boxes may be activated or deactivated. Pressing the C key activates or deactivates the selected checkbox.

In certain menus, parameters may be changed. These changes are made by pressing the  and  keys.

For all programming goes: Changes are applied and stored upon pressing the  key only, by pressing the  key you leave the menu without applying the changes.

To go to certain menus, entering a four-digit PIN is required. In the as-delivered condition, this PIN is 1111. Please change this PIN, if you want to avoid changes to the settings.

If a programming session has not been completed, the telephone leaves the Programming menu after a certain amount of time (time-out).

## Intrinsically safe telephone iVT3\*\*

The iVT3\*\* telephone can be used as a feature, alarm and shaft telephone. Using the Programming menu „Device profile“, the device type has to be set according to the area of operation. For setting the device type, a second, eight-digit PIN (PIN-M = Master PIN) is required. This is always prompted upon selecting the device profile. The eight-digit Master PIN is not documented in this operating manual. It can be obtained from FHF Bergbautechnik.

The displays and settings available in the menu, depends on the choice of device type.

In the factory, the iVT3\*\* has been set to the DSK standard variety, as follows:

Device profile:	Feature telephone
Equipment – coupler:	5210/3
Equipment – ext. loudspeaker:	5801K
Telephone – Ringer sound – Melody:	2
Telephone – Ringer sound – Volume:	6
Telephone – Volume – Handset - Listen:	5
Telephone – Volume – Handset - Speak:	1
Telephone – Volume – Loudspeaker	6
Telephone – Dialling mode:	DTMF unlimited
Telephone – PBX/PSTN – Prefix Entry:	Empty
Telephone – PBX/PSTN – T_Prefix_Pause:	1,25 s
Telephone – PBX/PSTN – T-flash:	125 ms
Contacts (Outputs) – Call relay – Switch on – Telephone call:	x
Contacts (Outputs) – Call relay – T-off-delay:	0 s
Menu language:	German
Menu – LCD contrast:	3

The menu structure of the individual device types is shown below:

**iVT3\*\* as feature telephone**

**Main menu**

- + Cycle time reg. (displayed if allocated to the loudspeaker key only)
- + Telephone book
  - +---->----+-- Dial
  - + Entry + Change Entry ..... (4-digit PIN entry required)
    - + Add Entry..... (4-digit PIN entry required)
    - + Delete Entry..... (4-digit PIN entry required)
    - + Delete All..... (4-digit PIN entry required)
- + Lock
  - + Activate..... (4-digit PIN entry required)
    - + (\*) Not Any
    - + ( ) Direct Call
    - + ( ) Total Lock
    - + ( ) Phone book
  - + Direct Call No -----> Number ..... (4-digit PIN entry required)
- + Settings
  - + Device profile ..... (8-digit PIN-M entry required)
    - + (\*) Feature Ph.
    - + ( ) Alarm Phone
    - + ( ) Shaft Phone
  - + Equipment
    - + Coupler..... (4-digit PIN entry required)
      - + (\*) 5210/3
      - + ( ) TA1
    - + Ext. Loudspeaker ..... (4-digit PIN entry required)
      - + ( ) Not any
      - + ( ) iLA3/16
      - + (\*) 5801K
  - + Telephone
    - + Ringer sound
      - + Melody -----> 0 .. 7 [2] ..... (4-digit PIN entry required)
      - + Volume -----> 0 .. 6 [6]..... (4-digit PIN entry required)
    - + Volume
      - + Handset
        - + Listen -----> 0 .. 6 [5] ..... (4-digit PIN entry required)
        - + Speak -----> 0 .. 6 [1] ..... (4-digit PIN entry required)
        - + Loudspeaker -----> 0 .. 6 [6]..... (4-digit PIN entry required)
    - + Dialing Mode ..... (4-digit PIN entry required)
      - + ( ) DTMF 90 ms
      - + (\*) DTMF unlim.
  - + PBX
    - + Prefix Number
      - + Prefix Entry -----> 1-digit code number ..... (4-digit PIN entry required)
      - + T\_Prefix\_pause -----> 1.00 .. 6.00 s [1.25] ..... (4-digit PIN entry required)
      - + T\_Flash -----> 40 .. 400 ms [125] ..... (4-digit PIN entry required)
- + Contacts
  - + Call relay
    - + Switch on ..... (4-digit PIN entry required)
      - + [X] Phone Call
      - + [X] Alarm Call
    - + T\_off\_delay. -----> 0.00 .. 9.00 s [0.00]..... (4-digit PIN entry required)
- + Menu
  - + Languages ..... (4-digit PIN entry required)
    - + (\*) German
    - + ( ) English
  - + Greeting-----> 1. line welcome message [FHF-BT] ..... (4-digit PIN entry required)
  - + LCD contrast --> 0 .. 9[3]..... (4-digit PIN entry required)
  - + Fact.Settings..... (4-digit PIN entry required)
  - + PIN -----> PIN 4-digit as-delivered condition 1111 ..... (4-digit PIN entry required)
  - + PIN-M -----> PIN 8-digit as-delivered condition xxxxxxxx ..... (8-digit PIN-M entry required)
- + Extras
  - + Cycle time reg.
    - + Activate..... (4-digit PIN entry required)
      - + [ ] yes
    - + WinCCServer -----> Number ..... (4-digit PIN entry required)
- Lift restrictions
  - + always ..... (4-digit PIN entry required)
  - + this time ..... (4-digit PIN entry required)

**iVT3\*\* as alarm telephone**

**Main menu**

- + Cycle time reg. (displayed if allocated to the loudspeaker key only)
- + Telephone book
  - +----->-----+-- Dial
  - + Entry -+ + Change Entry ..... (4-digit PIN entry required)
  - + Add Entry ..... (4-digit PIN entry required)
  - + Delete Entry ..... (4-digit PIN entry required)
  - + Delete All ..... (4-digit PIN entry required)
- + Settings
  - + Device profile ..... (8-digit PIN-M entry required)
  - + ( ) Feature Ph.
  - + (\*) Alarm Phone
  - + ( ) Shaft Phone
  - + Equipment
    - + Ext. Loudspeaker. .... (4-digit PIN entry required)
    - + ( ) Not any
    - + ( ) iLA3/16
    - + (\*) 5801K
  - + Telephone
    - + Ringer sound
      - + Melody -----> 0 .. 7 [2] ..... (4-digit PIN entry required)
      - + Volume -----> 0 .. 6 [6] ..... (4-digit PIN entry required)
      - + CallSig Length
        - + T\_signal\_min -----> 0.1 .. 10.0 s [0.2] ..... (4-digit PIN entry required)
        - + T\_signal\_max -----> 0.1 .. 10.0 s [2.1] ..... (4-digit PIN entry required)
    - + Volume
      - + Handset
        - + Listen -----> 0 .. 6 [5] ..... (4-digit PIN entry required)
        - + Speak -----> 0 .. 6 [1] ..... (4-digit PIN entry required)
      - + Loudspeaker -----> 0 .. 6 [6] ..... (4-digit PIN entry required)
    - + Dialing Mode ..... (4-digit PIN entry required)
      - + ( ) DTMF 90 ms
      - + (\*) DTMF unlim.
  - + PBX
    - + Prefix Number
      - + Prefix entry -----> 1-digit code number ..... (4-digit PIN entry required)
      - + T\_Prefix\_pause -----> 1.00 .. 6.00 s [1.25] ..... (4-digit PIN entry required)
      - + T\_Flash -----> 40 .. 400 ms [125] ..... (4-digit PIN entry required)
  - + Alarm call
    - + Ringer sound
      - + Melody -----> 0..7 [7] ..... (4-digit PIN entry required)
      - + Volume -----> 0..6 [6] ..... (4-digit PIN entry required)
      - + CallSig Length
        - + T\_signal\_min -----> 0.1 .. 10.0 s [2.2] ..... (4-digit PIN entry required)
        - + T\_signal\_max -----> 0.1 .. 10.0 s [2.9] ..... (4-digit PIN entry required)
        - + T\_pause\_max -----> 0.1 .. 10.0 s [2.9] ..... (4-digit PIN entry required)
      - + No. of Rings -----> 2 .. 9 [2]
    - + Options
      - + [ ] Acknowledge ..... (4-digit PIN entry required)
  - + Emergency call
    - + Emerg Call Num -----> Number ..... (4-digit PIN entry required)
    - + Options
      - + [ ] Lp Curr rev ..... (4-digit PIN entry required)
  - + Battery test
    - + Ringer Sound
      - + CallSig Length
        - + T\_signal\_min -----> 0.1 .. 10.0 s [4.2] ..... (4-digit PIN entry required)
        - + T\_signal\_max -----> 0.1 .. 10.0 s [4.6] ..... (4-digit PIN entry required)
    - + Good digit -----> Code number [1] ..... (4-digit PIN entry required)
    - + Error digit -----> Code number [0] ..... (4-digit PIN entry required)
  - + Contacts
    - + Call Relay
      - + Switch on ..... (4-digit PIN entry required)
        - + [X] Phone Call
        - + [ ] Alarm Call
      - + T\_off\_delay -----> 0.00 .. 9.00 s [0.00] ..... (4-digit PIN entry required)
    - + Alarm relay
      - + Switch on ..... (4-digit PIN entry required)
        - + [X] Alarm call
  - + Menu
    - + Language ..... (4-digit PIN entry required)
      - + (\*) German
      - + ( ) English
    - + Greeting-----> 1. line welcome message [FHF-BT] ..... (4-digit PIN entry required)

## Intrinsically safe telephone iVT3\*\*

- | +- LCD-contrast --> 0 .. 9[3]..... (4-digit PIN entry required)
- | +- Fact. Settings..... (4-digit PIN entry required)
- | +- PIN -----> PIN 4-digit as-delivered condition 1111..... (4-digit PIN entry required)
- | +- PIN-M -----> PIN 8-digit as-delivered condition xxxxxxxx ..... (8-digit PIN-M entry required)
- + Extras
  - + Cycle time reg.
  - + Activate..... (4-digit PIN entry required)
  - | +- [ ] yes
  - + WinCCServer -----> Number ..... (4-digit PIN entry required)

## iVT3\*\* as shaft telephone

### Main menu

- + Settings
  - + Device profile ..... (8-digit PIN-M entry required)
    - | +- ( ) Feature Ph.
    - | +- ( ) Alarm Phone
    - | +- (\*) Shaft Phone
  - + Equipment
    - | +- Ext. loudspeakr. .... (4-digit PIN entry required)
      - | +- ( ) Not any
      - | +- ( ) iLA3/16
      - | +- (\*) 5801K
  - + Telephone
    - | +- Ringer Sound
      - | +- Melody -----> 0 .. 7 [2]..... (4-digit PIN entry required)
      - | +- Volume -----> 0 .. 6 [6]..... (4-digit PIN entry required)
      - | +- Ringing Sequence
        - | +- T\_signal -----> 0.1 .. 10.0 s [1.0] ..... (4-digit PIN entry required)
        - | +- T\_pause -----> 0.1 .. 10.0 s [3.0] ..... (4-digit PIN entry required)
        - | +- No. of calls -----> 1 .. 255 [10]
    - | +- Volume
      - | | +- Handset
        - | | | +- Listen -----> 0 .. 6 [5]..... (4-digit PIN entry required)
        - | | | +- Speak -----> 0 .. 6 [1] ..... (4-digit PIN entry required)
        - | | +- Loudspeaker -----> 0 .. 6 [6] ..... (4-digit PIN entry required)
      - | +- Dialing Mode ..... (4-digit PIN entry required)
        - | +- ( ) DTMF 90 ms
        - | +- (\*) DTMF unlim.
      - | +- Identities
        - | +- DeviceID -----> Number 2-digit ..... (4-digit PIN entry required)
        - | +- GroupID -----> Number 2-digit ..... (4-digit PIN entry required)
    - + Contacts
      - | +- Call relay
        - | +- Switch on ..... (4-digit PIN entry required)
          - | | +- [X] Telephone call
          - | | +- [ ] Alarm Call
        - | +- T\_off\_delay -----> 0.00 .. 9.00 s [0.00]..... (4-digit PIN entry required)
    - + Menu
      - + Language ..... (4-digit PIN entry required)
        - | +- (\*) German
        - | + ( ) English
      - + Greeting-----> 1. line welcome message [FHF-BT] ..... (4-digit PIN entry required)
      - + LCD contrast --> 0 .. 9[3]..... (4-digit PIN entry required)
      - + Fact.Settings ..... (4-digit PIN entry required)
      - + PIN -----> PIN 4-digit as-delivered condition 1111 ..... (4-digit PIN entry required)
      - + PIN-M -----> PIN 8-digit as-delivered condition xxxxxxxx ..... (8-digit PIN-M entry required)

**Description of the menu items**

**Cycle time registration**                      If this menu item is selected, the iVT3\*\* can be used for the cycle time registration in the driving technology underground.

**Telephone book**                                The telephone contains a telephone book for storing up to 47 names and numbers.

The telephone book can be programmed as follows:

- Change entry                                    An existing entry is changed.
- Add entry                                        A new entry is added to the telephone book.
- Delete entry                                    An existing entry is deleted.
- Delete all entries                              The complete telephone book is deleted.

**Lock**                                                This menu item is shown in the device setting (device profile) „Feature telephone“ only.

Under this menu item you can perform the following programming operations:

- Not any                                         All restrictions are lifted.
- Direct call                                      When Direct call is set, pressing any key (except the „NO“, „Disconnect“ and „Loudspeaker“ keys) always dials the stored direct call number.
- Enter number                                    The direct call number is programmed.
- Activate Direct call                            Direct call is activated.
- No calls                                         The telephone is restricted. No calls can be made. Calls may be received.
- Telephone book                                Numbers may be called from the telephone book only.

If use of the telephone is restricted, the restrictions may be lifted by pressing the “NO” key. The menu item „Lift restrictions“ is displayed. Selecting the item „always“ lifts all restrictions. Selecting the item „this time“ lifts the restrictions for this call only. After replacing the handset, the restrictions are again active. For lifting the restrictions, entering the four-digit PIN is required.

**Settings**

Under this menu item you can perform the following programming operations:

- Device profile                                    The telephone is configured as Feature, Alarm or Shaft telephone. Following configuration, only the settings belonging to the chosen device profile are accessible.
- Equipment
  - Coupler                                         When selecting the Feature telephone configuration, you must de-select the telephone coupler with which the telephone is operated. 5210/3 stands for 2323, sB2248 and sG2148  
TA1 stands for KT1, iKT1-A2
  - Ext. loudspeaker                              You may choose between no loudspeaker („none“) (power amplifier is switched off) or the loudspeaker types iLA3/16 or 5801K.
- Telephone
  - Ringer Sound                                    The melody (0...7) and the volume (0...6) of the telephone are set. Setting the receiving volume of the handset, the mouthpiece volume of the handset, and that of the loudspeaker.
  - Volume
  - Dialling Mode                                    The duration of the dual-tone multifrequency dialling signal is set to 70 ms, 90 ms or unlimited (corresponding to the time the key is pressed).
  - PBX                                                Entering the Prefix Number. The duration of the pause (1..6 s) following the Prefix Number and the duration of the flash signal (40...400 ms) are set.

- Outputs
  - Call relay                      The potential-free output contact CALL is activated or deactivated. A bridging of call pause (0...9s) can be set.
- Menu
  - Languages                      The menu language is set to German or English.
  - Greeting                      The text of the first display line is displayed when occupying a line.
  - LCD contrast                  Setting the display contrast.
  - Fact setting                    The as-delivered condition is reset.
  - PIN                              Setting the four-digit PIN.
  - PIN-M                          Setting the eight-digit Master PIN.

Please note: When resetting to the as-delivered condition, the PINs and the menu language are not changed.

**Extras**

- Under this menu item you can perform the following programming operations:
- Cycle time reg.
  - Activate                      The terminal function is activated.
  - WinCC Server                Entering the number of the WinCC Server.

**Special menu items of the alarm telephone**

In the case of the alarm telephone, we differentiate between the normal call, alarm call and test call (battery test). The difference consists in the duration of the ringing signal on the remote line.

- Telephone
  - Ringer Sound
    - CallSig Length              The detection area (duration / length of the ringing signal) is set for the normal call.
- Alarm call
  - Ringer Sound
    - CallSig Length              The detection area (duration / length of the ringing signal) is set for the alarm call. The duration of the pause between the ringing signals is set. The number of call until the call is switched to the alarm announcement is set.
  - Options                      The possibility to acknowledge an alarm call can be activated or deactivated.
- Emergency call                Entering the emergency call target. Optionally, in case of an emergency call, the loop current which is applied to the remote line, can be inverted.
- Battery test
  - Ringer Sound
    - CallSig Length              The recognition area (duration of the ringing signal) is set for the test call (battery test).
    - Good digit                    Entering the good digit (1 character) as a feedback on the test call.
    - Error digit                    Entering the error digit (1 character) as a feedback on the test call.
- Contacts
  - Call relay                      The potential-free output contact CALL is activated or deactivated. A bridging call pause (0...9s) can be set.
  - Alarm relay                    The potential-free output contact ALARM is activated or deactivated.

**Special menu items of the shaft telephone**

- Telephone
  - Identities                      Entering the two-digit number of the telephone and the two-digit number of the group call.

### The iVT3\*\* as alarm telephone

The iVT3\*\* can be used as an alarm telephone in the intrinsically safe alarm telephone system TA1 in the hard coal mining industry. With means of an telephone coupler (printed circuit board inserted in alarm controller / coupler cabinet) iKT1-A2 and an alarm computer (ATAR), the iVT3\*\* can be used for emitting / distribution of alarm signals followed by an announcement.

If the iVT3\*\* is equipped with an external emergency key, and the emergency call function has been activated by the programming of an emergency call number, pressing the emergency call key initiates a connection to an emergency telephone (red telephone).

For regular / cyclic monitoring purposes the telephone can be tested once every day at a time when the telephone activity is low (e.g. in the night). This includes testing of both the state (voltage) of the battery and the quality (attenuation) of the telephone-network line.

For additional visualisation / acoustical signalling of the ringing signal and/or the alarm signal in loud areas, intrinsically safe electric circuits can be actuated by two potential-free opto-coupler outputs.

In addition, an intrinsically safe blink lamp iBL1 for visual call signalling can be connected. It is supplied by the battery or the rechargeable battery of the iVT3\*\*.

#### Alarm telephone actions

##### Breaking-in

If an alarm call shall be emitted, the alarm computer takes the necessary steps to interrupt and terminate the existing connections in the TA1 alarm controller / coupler cabinet. After that a separate connection of this telephone lines is established to the alarm bus bar. This alarm bus bar is a common audio frequency (AF) route. In the telephone coupler iKT1-A2, the DC loop current of the iVT3\*\* is interrupted. The LF connection (alarm call signalling and announcement) remains. If the iVT3\*\* detects the applied first ringing signal as an alarm sequence, a loud alarm signal is emitted over the internal and external loudspeakers. Following the last alarm call, the alarm signal is no longer emitted and the telephone-network line is connected to the iVT3\*\*'s loudspeaker amplifier. The number of alarm signal sequences till changeover to alarm-announcement is parameterisable.

##### Text announcement

Following the alarm, the alarm text is fed to the alarm bus bar and loudly emitted over the iVT3\*\*'s loudspeakers. By means of the parameterisation of the loudspeaker volume, the distribution volume can be adapted to the ambient sound pressure level.

During the alarm state, the opto-coupler outputs of the iVT3\*\* can be actuated.

An confirmation at site of the alarm can be parameterised in the ATAR. In this case, the emergency key of the iVT3\*\* is used as confirmation key during a text announcement.

##### Complete the alarm

The duration of the alarm condition is defined by the alarm computer (ATAR). If the alarm computer terminates the alarm, the current loop of the telephone-network lines is re established in the telephone couplers. Upon detection of the loop current as end of the alarm state, the iVT3\*\* switches over to the operation mode „Stand-by“.

##### Emergency call

Pressing the external emergency key initiates a connection to a special emergency telephone. An emergency call number stored in the iVT3\*\*, e.g. „777“ is dialled by it automatically.

At the same time, this emergency call is registered and evaluated by the alarm computer.

##### Pressing the emergency call key in Stand-by mode

Pressing the emergency call key, activates the iVT3\*\* and switches it over to the “Emergency call” mode. The telephone-network line is occupied by a loop current with the opposite polarity of the normal one. This mode is detected by the telephone coupler iKT1-A2 and the corresponding iKT1-Controller. This enables the ATAR to detect the iVT3\*\*, which is making the emergency call, even if its Handset is on the hook. Subsequently, the iVT3\*\* dials the stored emergency call number. The telephone exchange therefore establishes the connection to the emergency telephone (red telephone). If the person making the emergency call is no longer able to lift the Handset and continue or terminate the call, the iVT3\*\* terminates it automatically after a waiting time of two minutes and returns to stand-by mode.

### **The iVT3\*\* as alarm telephone**

#### Pressing the emergency key in Call mode

If, at the time the emergency call key is being pressed, the iVT3\*\* is just receiving a call, the telephone-network line is first occupied and then immediately disconnected / interrupted. The telephone-network line is then accessible, and the emergency call number can be dialled by the iVT3\*\*.

#### Pressing the emergency call key during a normal connection is established

The iVT3\*\* interrupts the connection for two seconds. The telephone-network line is then accessible, and the emergency call number can be dialled by the iVT3\*\*.

#### Pressing the emergency call key in alarm or test mode

In these special cases, the direct emergency call has lower priority than an alarm or test call. Here, there is no possibility to occupy the loop and establish a call connection to the emergency telephone. The pressing of the emergency call key is buffered. There is, however, no possibility to use the emergency call key as a confirmation key for an alarm call. In this case, an emergency call cannot be detected as such or be processed, until the alarm announcement has been completed. In case of a test call, the emergency call is processed immediately after completion of the test.

#### Test

At a time when activity is low, the iVT3\*\* telephone can be remote tested for function. This test is performed by the alarm computer making a test call. The result (test response) is protocolled by the alarm computer.

For test purposes, the iVT3\*\* is disconnected from the private branch exchange in the coupler cabinet. During the test procedure in progress, neither calls nor emergency calls can be made with the corresponding iVT3\*\*.

The test involves applying a 300 Hz ringing signal to the telephone-network line for a specified amount of time. If length of the test call corresponds to the programmed value in the iVT3\*\*, the iVT3\*\* returns a test response (DTMF digit corresponding to state of the battery voltage ( Good / Bad).

### iVT3\*\* as shaft telephone

In a shaft telephone exchange all shaft telephones are connected to a common communications line (party-line). The physical wiring to the exchange, however, is star-shaped.

To start a call to a certain telephone, it is required to lift the Handset and dial the number of the wanted subscriber. Due to the commonly used, only once present, communications channel, the „switching“ and the call are not governed by an automatic exchange (as in a normal private branch exchange), but by certain functions that have been redeployed to the telephones.

The shaft telephones are not called and identified via the corresponding port and network-telephone line of a PBX, but via an individual number programmed in each and every telephone device iVT3\*\*. If the location of a wanted person is unknown, you may use the “Group call” (number 99) to establish this. Thus all telephones connected to the party-line emit the ringing signal.

The shaft telephone appliance / system has no “Occupied” or “Busy” mode. Any subscriber can simply break into an established connection (session), simply by lifting his Handset.

When the user lifts the Handset, the iVT3\*\* is activated, and feeds a loop current in the direction of the exchange (consisting of telephone couplers iKT1-A2 and some corresponding electronic modules) of the shaft telephone system.

The telephone coupler iKT1-A1 (or the telephone coupler KT1, which may be used as an alternative) detects this loop current and then connects the non-intrinsically safe loop to the exchange. Thus, the activated telephone is connected to the exchange, and also to the 540 Hz tone frequency receiver / detector F2-E2, which is installed there.

The activated iVT3\*\* now generates a 540 Hz signal (attention tone) for a preset time of two seconds. When the tone frequency detector F2-E2 in the exchange receives this signal, it turns on a relay module, which switches the telephone lines over to the output of the call voltage transformer RTR1 of the exchange.

The so generated ringing signal is fed into all ports of the connected telephone couplers. The ringing signal is transformed by the telephone couplers into an intrinsically safe 300 Hz ringing signal and sent via all connected telephone lines to the shaft telephones.

After a delay time of about one second, the relay is de-energized, and the start sequence is completed. With the detection of the 300 Hz signal, the iVT3\*\*'s are activated. This activating time is preset to ten seconds. During this activating time, the shaft telephones are ready to receive their identity number, consisting of two digits and transferred by DTMF tones.

After lifting the handset, the subscriber making a call, can enter the desired number using the keypad of his telephone. In case the start sequence is still not completed, the iVT3\*\* buffers this number until the other shaft telephones are ready to receive, and then sends it out.

The iVT3\*\*, which receives and detects its number (or that of a group call), activates its loudspeaker and emits the acoustic ringing signal with a preset tone, a preset pause duration and a preset number or repetitions. If the handset is lifted on the telephone being called, the connection / session is established, and the desired conversation can take place.

If no one lifts the handset on the called telephone, the iVT3\*\* returns to Stand-by mode after a predefined number of ringing signals has been distributed.

The telephones that have not been called also return to Stand-by mode, approx. ten seconds after the 300 Hz ringing signal was finished. It is, however, always possible to break into an existing conversation simply by lifting the handset. The corresponding telephone will initiate the start sequence, but not interrupt the existing connection. A call ends when the handsets are returned to their hooks. Then the individual telephones return to stand-by mode, as does the entire system.

Please note: After placing the handset on the hook, there is a dead time of two seconds, during which the iVT3\*\* cannot be activated.

A shaft telephone system can also be built as entire intrinsically safe system type iST for operation, for example, in blind shafts by use of the intrinsically safe telephone couplers type iKT2.

For further information please refer to the operation instructions of intrinsically safe telephone coupler type iKT2, telephone coupler station Type iST-ST\* and intrinsically safe shaft telephone system type iST.

## Intrinsically safe telephone iVT3\*\*

### Warnings and security information

<p>The intrinsically safe telephone iVT3** is designed for operation in Group I hazardous atmospheres.</p> <p>Prior to installation, setup for operation or inserting the associated battery or rechargeable battery module, please note the following:</p>				
<p>The installation and adjustment of the device must be carried out by instructed and qualified personnel in accordance with the prescribed installation regulations taking the specified protection class into account. The requirements for safe use mentioned in the test certificates must be observed.</p>				
<p>If the device is installed in an accordingly certified, intrinsically safe system, and supplied via an electric supply circuit of category I M 2, type of protection EEx ib I or category I M 2, type of protection EEx ia I, the user must ensure that, should an hazardous atmosphere (increased level of firedamp) occur, this electric supply circuit is turned off, thus rendering the charging connections for the accumulator DC+ and DC</p>				
<p>The connection with other electric devices have to be separately approved and certified.</p>				
<p>The device is intended for use in hazardous mining areas.</p>				
<p>The device may only be connected to and operated at the voltage it was designed for. Please observe the information regarding polarity.</p>				
<p>The required modes of operation must be observed.</p>				
<p>Take care not to damage the housing.</p>				
<p>While operating the device in business or industry facilities, the legally required precautions against accidents resulting from the use of electrical systems and devices must be taken.</p>				
<p>The device may be operated solely under the stated ambient conditions. Unfavourable ambient conditions can lead to damage of the device and thus present a potential danger for the user. Such unfavourable ambient conditions could include:</p> <ul style="list-style-type: none"> <li>• Humidity of air too high (&gt;75% rel., condensing)</li> <li>• moisture, dust (pay attention to the degree of protection)</li> <li>• flammable gases, vapours, solvents not covered by the type of protection</li> <li>• too high ambient temperatures (&gt;+40 °C)</li> <li>• too low ambient temperatures (&lt; -20 °C for battery module type 9704U6;</li> <li>• &lt; 0 °C for rechargeable battery module type 9704U8)</li> </ul>				
<p>The device temperature must not exceed nor fall below the prescribed range of ambient temperatures during operation (-20°C to +40°C, or 0°C to +40°C, respectively), storage or transport (-20°C to +60°C).</p>				
<p>Please pay attention to the required operating position of the device.</p>				
<p>Cable and conductor entry parts (cable glands) may be used only as prescribed by the manufacturer.</p>				
<p>Repairs may be solely carried out by the manufacturer or by a person appointed by the manufacturer followed by a renewed product conformity inspection.</p>				
<p>Only certified, intrinsically safe battery or rechargeable battery modules may be used as replacements parts. The modules listed below are certified:</p> <table style="width: 100%; border: none;"> <tr> <td style="padding-left: 40px;">Battery module type 9704U6 with 9 V / 15 Ah</td> <td style="text-align: right;">(P/N 118 895 01 AX)</td> </tr> <tr> <td style="padding-left: 40px;">Rechargeable battery module type 0704U8 with 7.2 V / 0.5 Ah</td> <td style="text-align: right;">(P/N 118 896 01 AX)</td> </tr> </table>	Battery module type 9704U6 with 9 V / 15 Ah	(P/N 118 895 01 AX)	Rechargeable battery module type 0704U8 with 7.2 V / 0.5 Ah	(P/N 118 896 01 AX)
Battery module type 9704U6 with 9 V / 15 Ah	(P/N 118 895 01 AX)			
Rechargeable battery module type 0704U8 with 7.2 V / 0.5 Ah	(P/N 118 896 01 AX)			

**Warnings and security information**

During transport, storage and in unused condition, the device must be protected from damage. Disconnect the battery or the rechargeable battery module in order to prevent a premature discharge.

When storing the telephone, the battery plug connectors should be separated.

If necessary, additional precautions should be taken to protect the telephone against dirt, moisture and falling objects.

It is prohibited to mount further parts in or on the device.

**Warning:**

Should these points not be observed, the explosion protection can no longer be guaranteed.

The device is capable of producing a very high sound pressure level. In order to prevent hearing damage, avoid too close proximity to the activated loudspeaker.

**Requirements for safe use:**

The ambient temperature range of -20 °C to +40 °C is allowed when using the battery module type 9704U6 (primary batteries).

The ambient temperature range of 0 °C to +40 °C is allowed when using the rechargeable battery module type 9704U8 (rechargeable batteries).

**Disposal note:**

A defective or used, replaced battery or rechargeable battery module must be disposed of according to the relevant laws and regulations.