

## wST-MB weather-proof analogue telephone

- Resistant to temperature differences, humidity, seawater, acids, alkalis, greases, etc.
- High degree of protection IP 66 & impact resistance IK09
- Steel-armoured handset cord to withstand high tensile forces
- Robust, impact-resistant housing
- For demanding industrial, onshore and offshore applications
- V4A steel keypad, designed for use with gloves
- 3 freely programmable memory buttons for quick dialling
- Freely programmable, housing colour black
- Convenient telephone functions

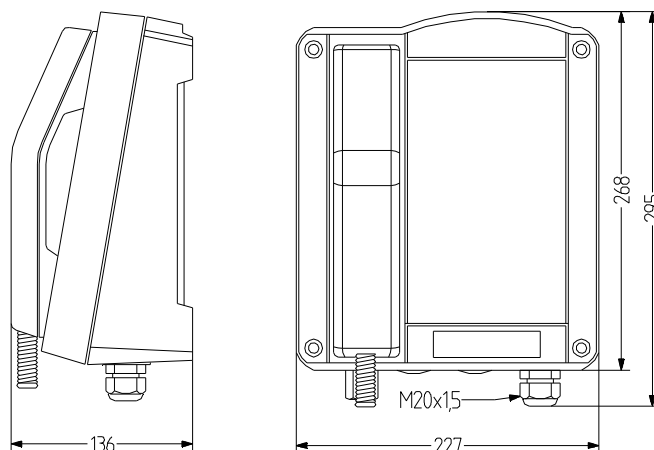

### TECHNICAL DATA

Dialling method	PD DTMF operation can be selected from menu DTMF operation as per CCITT recommendation Q.23 PD operation with pulse/pause ratio of 1.5:1 or 2:1, which can be selected via menu navigation
Tone ringing volume	90 dB
Transportation/storage temperature	-25 °C / +70 °C
Housing	glass-fibre-reinforced polyester black
Cable entry	1× M20 × 1.5, 2× blind plugs M20 × 1.5
Connection technology	up to 4 mm <sup>2</sup> rigid, up to 2.5 mm <sup>2</sup> flexible
Operating temperature	-25 °C / +60 °C
Degree of protection	IP66
Impact resistance	IK09
Technology	analogue
Keypad	Metal keypad with ice protection 21 keys with ABC lettering for name entries, 3 freely programmable memory keys enabling (emergency) telephone numbers to be dialled quickly

Noise suppression	> 3 dB thanks to integrated mouthpiece horn
Supply voltage	24 V DC - 66 V DC
Supply current	0,015 A DC-0,100 A DC
Ringing alternating current	24 V AC-90 V AC (at 21-90 Hz ringing frequency) 30 V AC-90 V AC (at 16.6-90 Hz ringing frequency)
Tone ringing impedance	> 6.0 KΩ at 25 Hz and 24-90 V AC > 4.0 KΩ at 50 Hz and 24-90 V AC
Enquiry key	Flash function can be adjusted from 40 ms-399 ms
W conductor	Option to connect external call signalling sounder
Weight	5,5 kg
Mouthpiece	Electret microphone
Receiver	dynamic receiver with leakage field spool for inductively coupling hearing aids
Stabiliser bracket	integrated, adjustable stabiliser protection
Handset cord	steel-reinforced armoured cord made of V4A



## wST-MB

## ORDER DATA

Housing colour	Order number
black	410 150 100



VS2



LS2



EP2



HS2



TCR



TH1



TH2

## ACCESSORIES

Type	Type of accessory	Colour	Housing material	Weight	Order number	
VS2	Visual-audible telephone call signalling sounder	black (RAL 9005)orange		935 g	410 201 005	
		black (RAL 9005)red		935 g	410 202 005	
		black (RAL 9005)clear		935 g	410 204 005	
		black (RAL 9005)blue		935 g	410 205 005	
		black (RAL 9005)green		935 g	410 206 005	
LS2	Loudspeaker set			1,1 kg	410 200 003	
EP2	Additional earpiece set			200 g	410 200 002	
HS2	Headset kit			410 g	410 200 001	
TCR	Weather-proof telephone switch relay			750 g	410 100 200	
TH1	Telephone sound protection hood	yellow (RAL 1023)	PVC – plastic (UV and weather-resistant)	30 kg	410 100 012	
			glass-fibre-reinforced plastic (GFRP)	40 kg	410 100 008	
			Console (sheet steel, powder-coated)	17 kg	410 100 011	
			Metal	35 kg	410 100 006	
		red (RAL 3020)	PVC – plastic (UV and weather-resistant)	30 kg	410 100 014	
			glass-fibre-reinforced plastic (GFRP)	40 kg	410 100 015	
			Metal	35 kg	410 100 009	
		orange (RAL 2000)	PVC – plastic (UV and weather-resistant)	30 kg	410 100 013	
			glass-fibre-reinforced plastic (GFRP)	40 kg	410 100 007	
		Stainless steel	Stainless steel	40 kg	410 100 010	
		TH2	Telephone sound protection hood	Stainless steel	3,5 g	410 100 020
				yellow	PVC – plastic (UV and weather-resistant)	3,5 g

