

! WARNING Bonding between conduit connections is not automatic and must be provided as part of the installation.

AVERTISSEMENT La connexion des masses n'est pas réalisée automatiquement par les raccordements des gaines et doit être prévue séparément lors de l'installation.

WARNUNG Die Verbindung zwischen Leitungsanschlüssen wird nicht automatisch hergestellt und muss bei der Installation erfolgen.

AVVERTENZA il collegamento a massa tra i connettori delle guaine non è automatico e deve essere previsto nell'ambito dell'installazione.

ATENÇÃO A ligação entre as conexões de conduíte não é automática e deve ser fornecida como parte da instalação.

ADVERTENCIA El enlace entre las conexiones del conducto no es automático y debe hacerse como parte de la instalación.

**ASS-T, ASM, ADS-T
ADM, ACM**

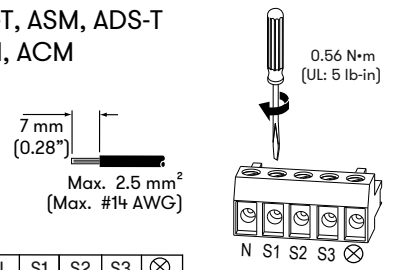

N	S1	S2	S3	⊗	
N	L				Stage 1
N	L			L	Stage 1 + ADS-T
N	x	L			Stage 2
N	x	L		L	Stage 2 + ADS-T
N	x	x	L		Stage 3
N	x	x	L	L	Stage 3 + ADS-T
N				L	ADS-T

ASS-P, ADS-P

La	N	Lb	
L	N		ASS-P, ADS-P
	N	L	ADS-P

ASL, ASX, ADL, ACL, ADX, ACX

La	N	Lb	
L	N		

ADM, ACM, ADL, ACL, ADX, ACX

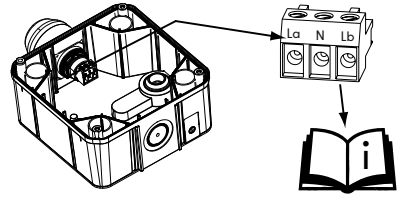

**Stage control; Sélection de la table de sons
Auswahl der Tontabelle; Selezione stage
Control de estado; Cableado de control**

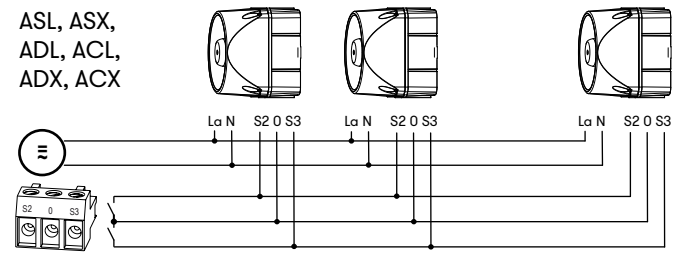
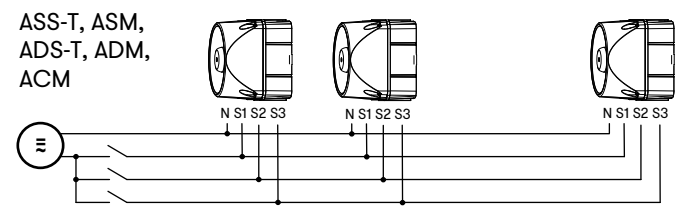

**Volume
Volume
Lautstärke
Volume
Volume
Volumen**

Not for ASX, ADX, ACX
Sauf pour ASX, ADX, ACX
Gilt nicht für ASX, ADX, ACX
Non valido per ASX, ADX, ACX
Não aplicável a ASX, ADX, ACX
No para ASX, ADX, ACX

S2	0	S3	
no connection			STAGE 1
			STAGE 2
			STAGE 3

Jumper, Cavalier, Brücke, Ponticello, Ponte, Puente

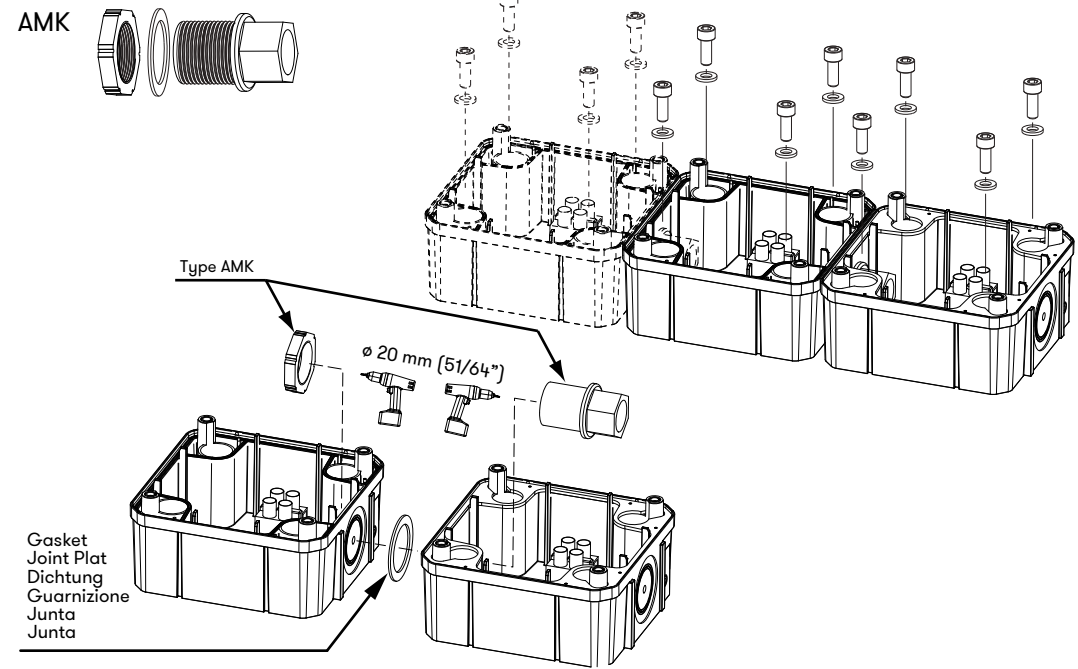
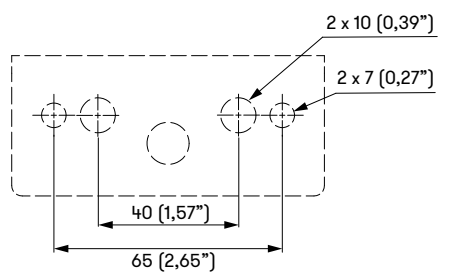
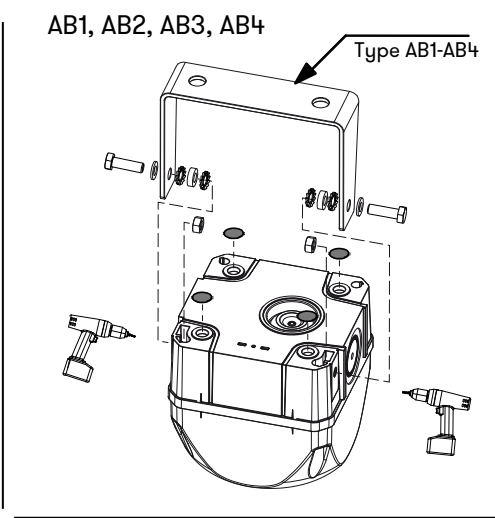
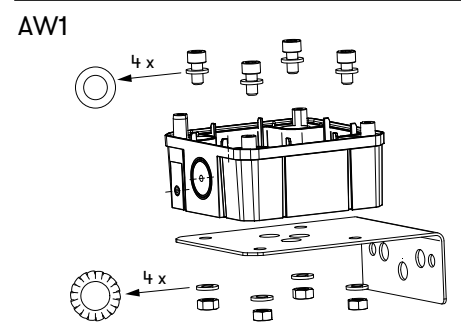
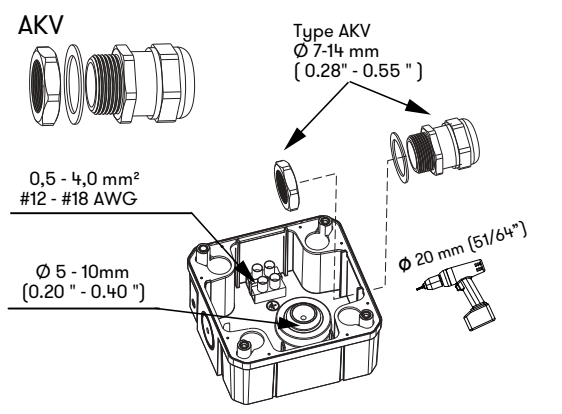

ASS-T, ADS-T, ASM, ASL, ASX, ADM, ACM, ADL, ACL, ADX, ACX

Tone selection
Sélection du son
Tonauswahl
Selezione tono
Selecção de tom
Selección de tono

Type
ASS-T, ADS-T, ASM,
ACM, ADM
ASL, ASX, ADL,
ACL, ADX, ACX



Loudness depending on frequency
Puissance sonore selon la fréquence
Lautstärke in Abhängigkeit von der Frequenz
Volume in funzione della frequenza
Volume (sonoridade) dependente da frequência
Volumen en base a la frecuencia

Variation +2dB / -3dB
Tolérance
Variation
variações
Variação
Variación

ADS-T
LED steady
feu LED fixe
LED Dauerlicht
luce LED fisso
luz LED continuo
Flashing light
Clignotante
Blinklicht
Lampeggiante
Intermittente

Tone table

Tone	STAGE 1 S1	Tone type	Frequency Hz	Pictogram	Repeat rate	Specific application	ASS-T/ADS-T	ASM	ASL	ASX	STAGE 2 S2	STAGE 3 S3
							max dB	max dB	max dB	max dB		
000000	Tone 01	continuous	660 Hz	=====		Swedish alarm	103	107	114	116	tone 16	tone 12
000000	Tone 02	continuous	1000 Hz	=====		PFEER toxic gas	97	110	113	121	tone 16	tone 25
000000	Tone 03	continuous	2400 Hz	=====			106	111	120	125	tone 21	tone 17
000000	Tone 04	intermittent	420 Hz	- - - - -	0,625 s on / 0,625 s off	Australian alert AS1670	98	106	109	117	tone 21	tone 01
000000	Tone 05	intermittent	660 Hz	- - - - -	1,8 s on - 1,8 s off	Swedish alarm	103	107	114	117	tone 21	tone 01
000000	Tone 06	intermittent	660 Hz	- - - - -	0,15 s on / 0,15 s off	Swedish alarm	103	107	114	117	tone 16	tone 01
000000	Tone 07	intermittent	970 Hz	- - - - -	1 s on, 1 sec off	PFEER Alarm, BS5839-1:2002	99	111	113	122	tone 18	tone 01
000000	Tone 08	intermittent	970 Hz (950)	- - - - -	0,5 s on/0,5 s off x 3 then 1 s off	ISO 8201 low tone, US Temporal	101	111	113	122	tone 16	tone 03
000000	Tone 09	intermittent	800 Hz	- - - - -	0,25 s on / 1 s off		108	112	112	124	tone 27	tone 03
000000	Tone 10	intermittent	700 Hz	- - - - -	0,15 s on / 0,15 s off, total 1 min.	Swedish alarm SS 031711	102	107	112	119	tone 18	tone 02
000000	Tone 11	intermittent	720 Hz	- - - - -	0,7 s on / 0,3 s off	Industrial Alarm Germany	102	110	111	123	tone 02	tone 29
000000	Tone 12	intermittent	2400 Hz	- - - - -	0,5 s on / 0,5 s off		106	111	120	126	tone 03	tone 01
000000	Tone 13	intermittent	2850 Hz	- - - - -	0,5 s on/0,5 s off x 3 then 1 s off	ISO 8201 high tone, US Temporal	97	108	111	120	tone 03	tone 17
000000	Tone 14	alternating	440 - 554 Hz	=====	0,4 s (440Hz) / 0,1 s (554Hz)	AFNOR France, NFS 32-001	103	109	109	118	tone 16	tone 01
000000	Tone 15	alternating	554 - 440 Hz	=====	1 Hz	Swedish alarm	103	109	109	118	tone 01	tone 16
000000	Tone 16	alternating	800 - 1000 Hz	=====	2 Hz		108	113	113	121	tone 02	tone 09
000000	Tone 17	alternating	2400 - 2900 Hz	=====	2 Hz		106	111	120	126	tone 03	tone 01
000000	Tone 18	alternating	1000 - 2000 Hz	=====	1 Hz	Singapore	107	110	120	127	tone 02	tone 03
000000	Tone 19	sweeping	500 - 1500 Hz	=====	10 Hz		108	113	119	124	tone 02	tone 01
000000	Tone 20	sweeping	150 - 1000 Hz	=====	rising 10 s, 40 s on, falling 10 s	Industrial Alarm Germany	108	113	114	123	tone 25	tone 29
000000	Tone 21	continuous	400 Hz	=====	simulated horn		101	106	109	115	tone 16	tone 02
000000	Tone 22	sweeping	500 - 1200 Hz	=====	rising in 3,75 s / 0,25 s off	Australian evacuation AS 2220	108	113	117	124	tone 02	tone 09
000000	Tone 23	sweeping	500 - 1200 Hz	=====	rising in 3,5 s / 0,5 s off	Netherlands NEN 2575:2000	108	113	117	124	tone 02	tone 09
000000	Tone 24	sweeping	500 - 1200 Hz	=====	0,5 s on/0,5 s off x 3 / 1,5 s off	Australia AS1670 evacuation	108	113	117	124	tone 02	tone 09
000000	Tone 25	sweeping	1200 - 500 Hz	=====	1 Hz	evacuation Germany, DIN 33404-3	108	113	117	124	tone 02	tone 32
000000	Tone 26	sweeping	500 - 1200 Hz	=====	0,3 Hz		108	113	117	124	tone 01	tone 32
000000	Tone 27	sweeping	1400 - 1600 Hz	=====	rising in 1 s/falling in 0,5 s	NFC 48-265	102	110	119	124	tone 02	tone 09
000000	Tone 28	sweeping	2400 - 2900 Hz	=====	1 Hz		106	111	120	126	tone 17	tone 03
000000	Tone 29	bell					102	108	120	122	tone 16	tone 02
000000	Tone 30	slow rise	500 - 2400 Hz	=====	siren rising in 3 s, then cont. 2400 Hz		108	113	120	127	tone 16	tone 01
000000	Tone 31	slow rise	300 - 1200 Hz	=====	siren rising in 3 s, then cont. 1200 Hz		108	113	117	124	tone 16	tone 01
000000	Tone 32	3-tone gong	660-550-440 Hz	=====	repeating 3-tone gong, 7s		90	93	X	X	tone 29	tone 01
000000		chime	970 - 800 Hz	=====	repeating ding-dong, 1 Hz		X	X	113	123	tone 29	tone 01
000000	Tone 33	continuous	340 Hz	=====			X	X	109	114	tone 16	tone 03
000000	Tone 34	continuous	500 Hz	=====			X	X	109	116	tone 16	tone 03
000000	Tone 35	continuous	825 Hz	=====			X	X	113	121	tone 16	tone 03
000000	Tone 36	continuous	1500 Hz	=====			X	X	118	126	tone 18	tone 02
000000	Tone 37	continuous	2850 Hz	=====			X	X	111	120	tone 21	tone 01
000000	Tone 38	intermittent	660 Hz	- - - - -	0,5 s on - 0,5 s off	Swedish alarm	X	X	114	117	tone 02	tone 32
000000	Tone 39	intermittent	680 Hz	- - - - -	0,875 s on-0,675 s off		X	X	114	117	tone 03	tone 32
000000	Tone 40	intermittent	950 Hz	- - - - -	1 s on, 1 s off		X	X	114	120	tone 02	tone 32
000000	Tone 41	intermittent	1000 Hz	- - - - -	1 s on-1 s off	PFEER General Alarm	X	X	113	122	tone 16	tone 03
000000	Tone 42	intermittent	800 Hz	- - - - -	4 ms on, 4 ms off		X	X	112	124	tone 58	tone 03
000000	Tone 43	intermittent	825 Hz	- - - - -	0,5 s on, 0,5 s off		X	X	113	122	tone 16	tone 03
000000	Tone 44	intermittent	825 Hz	- - - - -	2,5 s on, 2,5 s off x 7, then 7 s pulse	IMO SOLAS III/50+SOLAS III/6,4	X	X	113	121	tone 17	tone 02
000000	Tone 45	alternating	440 - 554 Hz	=====	1 Hz		X	X	109	116	tone 16	tone 01
000000	Tone 46	alternating	825 - 1075 Hz	=====	1 Hz		X	X	114	122	tone 48	tone 02
000000	Tone 47	alternating	825 - 1025 Hz	=====	2 Hz		X	X	114	122	tone 48	tone 03
000000	Tone 48	alternating	2500 - 3100 Hz	=====	0,5 Hz		X	X	117	125	tone 60	tone 03
000000	Tone 49	alternating	2400 - 2850 Hz	=====	2 Hz		X	X	120	126	tone 12	tone 03
000000	Tone 50	alternating	500 - 900 Hz	=====	2 Hz		X	X	114	120	tone 41	tone 02
000000	Tone 51	alternating	1200 - 1400 Hz	=====	25 Hz		X	X	119	124	tone 41	tone 02
000000	Tone 52	sweeping	300 - 1200 Hz	=====	1 Hz		X	X	117	124	tone 03	tone 32
000000	Tone 53	sweeping	500 - 1000 Hz	=====	0,15 Hz		X	X	114	122	tone 41	tone 02
000000	Tone 54	sweeping	500 - 1200 Hz	=====	3 Hz		X	X	117	123	tone 41	tone 02
000000	Tone 55	sweeping	700 - 1500 Hz	=====	0,3 Hz		X	X	119	125	tone 16	tone 02
000000	Tone 56	sweeping	800 - 1000 Hz	=====	7 Hz		X	X	114	123	tone 16	tone 02
000000	Tone 57	sweeping	800 - 1000 Hz	=====	50 Hz		X	X	114	90	tone 16	tone 02
000000	Tone 58	sweeping	2400 - 2900 Hz	=====	7 Hz		X	X	120	126	tone 17	tone 03
000000	Tone 59	sweeping	2400 - 2900 Hz	=====	50 Hz		X	X	120	90	tone 17	tone 03
000000	Tone 60	sweeping	2400 - 2900 Hz	=====	3 Hz		X	X	120	126	tone 17	tone 03
000000	Tone 61	slow rise	0 - 800 Hz	=====	siren rising in 3 s, then cont. 800 Hz		X	X	114	121	tone 16	tone 01
000000	Tone 62	chime	554 - 440 Hz	=====	repeating ding-dong, 1Hz		X	X	109	116	tone 29	tone 01
000000	Tone 63	chime	554 - 440 Hz	=====	single ding-dong		X	X	109	116	tone 29	tone 01