

WIND-IP weather-proof VoIP telephone

- For universal applications, resistant to high humidity, maritime climates, etc.
- (closed) & IP 65 (open)
- Impact-resistant polycarbonate housing
- Transparent protective door, eye-catching housing colour
- Standard protocol SIP (RFC3261)
- Integrated relay contact
- With visual LED call indicator
- Power over Ethernet or 24–48 V DC
- Visual-audible secondary sounder can be connected
- For wall mounting



TECHNICAL DATA

Tone ringing volume	90 dBDoor open: ~90 dB (A) at 1 m; door closed: ~65 dB (A) at 1 m
Power requirement	1,3 W
Connection	RJ45 port (10/100 Mbit/s)
Transportation/storage temperature	-40 °C / 70 °C
Housing	Polycarbonate yellow
Type of mounting	any
Cable entry	2× cable glands M16 × 1.5 for cable diameter of 5–9 mm
Operating temperature	-40 °C / +55 °C
Degree of protection	IP65 & IP66
Current supply	Power over Ethernet as per IEEE 802.3af or 24–48 V DC
Relay switching capacity	Bis zu 30 V AC oder 60 V DC 2 A < 30 V DC 1 A < 30 V DC 1 A < 30 V AC
Technology	VOIP
Protocol	SIP
Weight	2,3 kg (incl. bracket)
Mouthpiece	Electret microphone
Receiver	dynamic receiver

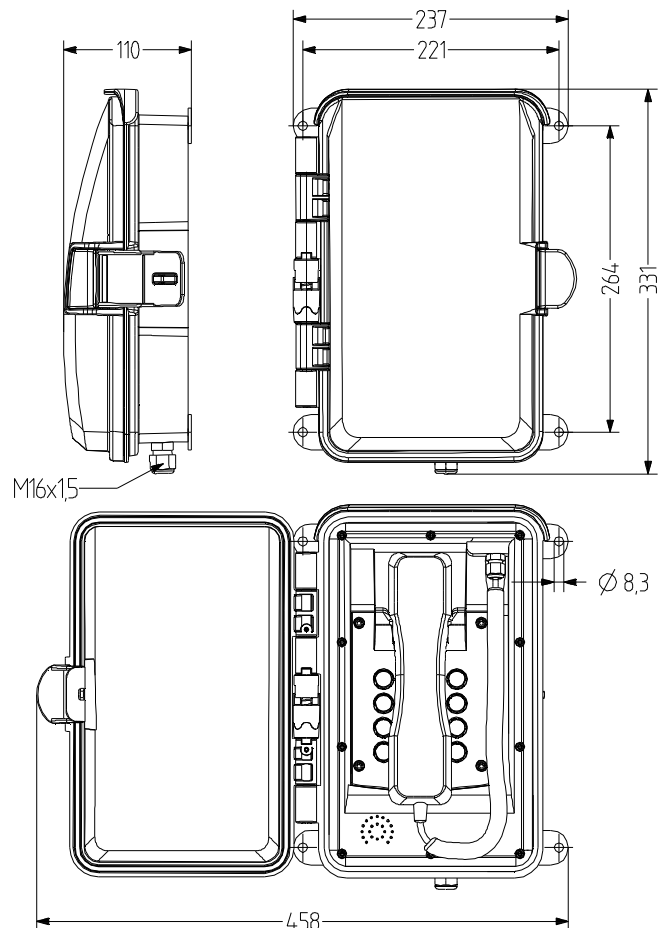

wIND-IP

ORDER DATA

Housing colour	Order number
yellow	410 750 000



VS2



TH1



TH2

ACCESSORIES



Type	Type of accessory	Colour	Housing material	Weight	Order number		
VS2	Visual-audible telephone call signalling sounder	black (RAL 9005)orange		935 g	410 201 005		
		black (RAL 9005)red		935 g	410 202 005		
		black (RAL 9005)clear		935 g	410 204 005		
		black (RAL 9005)blue		935 g	410 205 005		
		black (RAL 9005)green		935 g	410 206 005		
TH1	Telephone sound protection hood	yellow (RAL 1023)	PVC – plastic (UV and weather-resistant)	30 kg	410 100 012		
			glass-fibre-reinforced plastic (GFRP)	40 kg	410 100 008		
			Console (sheet steel, powder-coated)	17 kg	410 100 011		
			Metal	35 kg	410 100 006		
		red (RAL 3020)	PVC – plastic (UV and weather-resistant)	30 kg	410 100 014		
			glass-fibre-reinforced plastic (GFRP)	40 kg	410 100 015		
			Metal	35 kg	410 100 009		
		orange (RAL 2000)	PVC – plastic (UV and weather-resistant)	30 kg	410 100 013		
			glass-fibre-reinforced plastic (GFRP)	40 kg	410 100 007		
			Stainless steel	40 kg	410 100 010		
		TH2	Telephone sound protection hood	yellow	PVC – plastic (UV and weather-resistant)	3,5 g	410 100 030
					Stainless steel	3,5 g	410 100 020